

Blancett®

QUIKSERT® FLOW METER REPAIR KITS

OPERATION & INSTALLATION MANUAL



**8635 Washington Avenue
Racine, Wisconsin 53406**

Sales Toll-Free: 800.235.1638

Phone: 262.639.6770 Fax: 262.639.2267

www.blancett.com



TABLE OF CONTENTS

Introduction	3
Repair Kit Part Number Information	3
Turbine Meter Removal	4
Disassembly	4
Installation of New Kit	4
Illustrations	6
Statement of Warranty	7

NOTE: *Blancett reserves the right to make any changes or improvements to the product described in this manual at any time without notice.*

INTRODUCTION

The QuikSert® turbine flow meter is designed with wear resistant moving parts to provide trouble-free operation and long service life. The QuikSert® meter repair kit is designed for easy field service of a damaged flow meter, rather than replacing the entire flow meter. Repair parts are constructed of stainless steel alloy and tungsten carbide.

Each turbine meter repair kit is factory calibrated to ensure accuracy throughout the entire flow range. Each kit is complete and includes a new K-factor, which is the calibrated number of pulses generated by each gallon of liquid. This K-factor will be used to recalibrate the monitor, or other electronics, to provide accurate output data.

NOTE: If the meter repair kit part number ends in an “NCC” (no calibration), it was not factory calibrated. For these repair kits, use the nominal K-factor supplied.

REPAIR KIT PART NUMBER INFORMATION

Repair Kit Part Number	Flow Meter Size	Part Number
B253-102	$\frac{3}{8}'' \times 1''$	B131-038
B253-105	$\frac{1}{2}'' \times 1''$	B131-050
B253-108	$\frac{3}{4}'' \times 1''$	B131-075
B253-109	$\frac{7}{8}'' \times 1''$	B131-088
B253-112	$1'' \times 1''$	B131-100
B253-205	$\frac{1}{2}'' \times 2''$	B132-050
B253-208	$\frac{3}{4}'' \times 2''$	B132-075
B253-209	$\frac{7}{8}'' \times 2''$	B132-088
B253-212	$1'' \times 2''$	B132-100
B253-216	$1\text{-}\frac{1}{2}'' \times 2''$	B132-150
B253-220	$2'' \times 2''$	B132-200
B253-330	$3'' \times 3''$	B133-300
B253-440	$4'' \times 4''$	B134-400
B253-660	$6'' \times 6''$	B136-600
B253-880	$8'' \times 8''$	B138-800
B253-990	$10'' \times 10''$	B139-900
B111109	Standard Magnetic Pick-up	All Meter Sizes

TURBINE METER REMOVAL

WARNING: *High pressure leaks are dangerous and may cause personal injury. Make sure that fluid flow has been shut off and pressure in the line released before attempting to remove the meter.*

DISASSEMBLY

Refer to **Figures 1 and 2** on page 6 for relative positions of repair kit components.

1. Remove the magnetic pick-up from the meter body to avoid damage during repair.
2. Remove the retaining ring from one end of the meter.
NOTE: 2" and larger are held in by retaining screws.
3. Remove the rotor support from the body. If the rotor support is jammed in the body, use a pair of pliers or vise-grips to break the rotor support free.
4. The rotor may also be removed at this time.
5. Remove the retaining ring from the opposite side of the meter.
NOTE: 2" and larger are held in by retaining screws.
6. Remove the second rotor support.

INSTALLATION OF NEW KIT

IMPORTANT: Before reassembly, note that an arrow is cast or engraved on each component (see Note on page 6). The arrow indicates the direction of flow. The meter must be reassembled with arrowheads pointed in the direction of the fluid flow. The arrows are to be oriented in the up position on both rotor supports. The magnetic pick-up side of the body signifies the up position. This is the position that the repair kit was calibrated, and this is the position it is to be used to ensure meter accuracy.

Figures 1 and 2 on page 6 show the proper alignment and orientation of the repair kits.

NOTE: Fractional size ($\frac{3}{8}$ ", $\frac{1}{2}$ ", $\frac{3}{4}$ " & $\frac{7}{8}$ ") rotors do not contain a cast or engraved arrow. However, a colored cap is provided on the **downstream side** of the rotor shaft to indicate flow direction. Remove this cap before assembly, noting flow direction.

1. Install one of the rotor supports into the body bore, noting the orientation of the arrow.
2. Secure a retaining ring in the groove provided. Be sure that retaining rings are completely installed in each groove.

NOTE: 2" and larger meters will have retaining screws on both ends of the meter (**Figure 2** on page 6).

3. Insert the rotor and second rotor support in the opposite side of the body, noting the orientation of the arrow.
4. Secure the second retaining ring in the opposite groove.

NOTE: 2" and larger meters will have retaining screws on both ends of the meter (**Figure 2** on page 6).

5. Check the meter by blowing air through the assembly. If the rotor does not turn freely, the meter should be disassembled and checked for anything that would obstruct movement of the rotor.

CAUTION: *Excess air pressure may damage the rotor and bearings by over spinning.*

6. Install the magnetic pick-up.

NOTE: *At this time electronics will need recalibration. Refer to the proper installation and operation manual. If there are any questions on recalibration, contact the Blancett factory or the manufacturer of the associated electronics.*

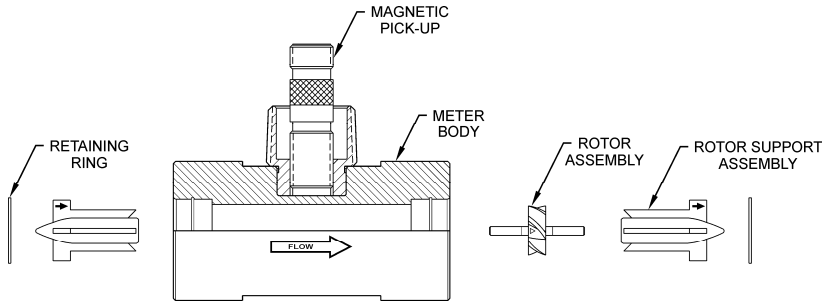

FIGURE 1 - Relative positions of internal components for all QuikSert meter sizes B131-038 through B131-100

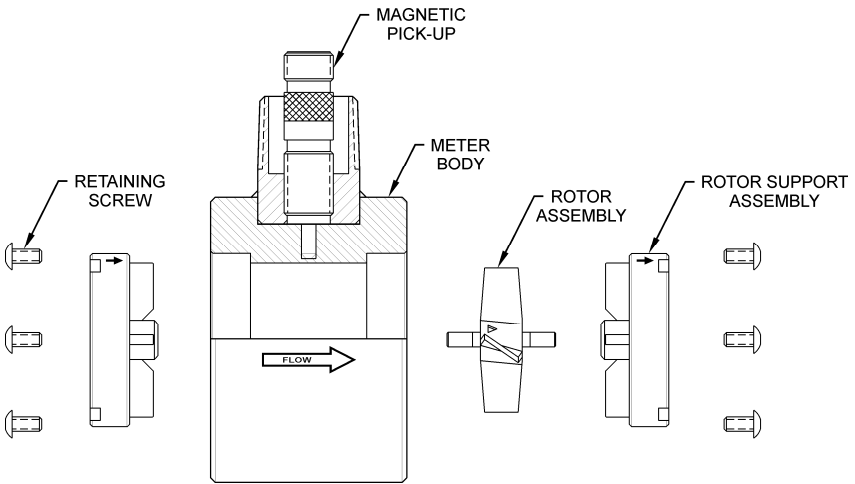

FIGURE 2 - Relative positions of internal components for all QuikSert meter sizes B132-050 through B139-900

STATEMENT OF WARRANTY

Blancett Flow Meters, Division of Racine Federated Inc. warrants to the end purchaser, for a period of one year from the date of shipment from the factory, that all flow meters manufactured by it are free from defects in materials and workmanship. This Warranty does not cover products that have been damaged due to defects caused by misapplication, abuse, lack of maintenance, modified or improper installation. Blancett's obligation under this warranty is limited to the repair or replacement of a defective product, at no charge to the end purchaser, if the product is inspected by Blancett and found to be defective. Repair or replacement is at Blancett's discretion. A return goods authorization (RGA) number must be obtained from Blancett before any product may be returned for warranty repair or replacement. The product must be thoroughly cleaned and any process chemicals removed before it will be accepted for return.

The purchaser must determine the applicability of the product for its desired use and assumes all risks in connection therewith. Blancett assumes no responsibility or liability for any omissions or errors in connection with the use of its products. Blancett will under no circumstances be liable for any incidental, consequential, contingent or special damages or loss to any person or property arising out of the failure of any product, component or accessory.

All expressed or implied warranties, including **the implied warranty of merchantability and the implied warranty of fitness for a particular purpose or application are expressly disclaimed** and shall not apply to any products sold or services rendered by Blancett.

The above warranty supersedes and is in lieu of all other warranties, either expressed or implied and all other obligations or liabilities. No agent or representative has any authority to alter the terms of this warranty in any way.

Blancett[®]

8635 Washington Avenue • Racine, Wisconsin 53406

Toll-Free: 800.235.1638

Phone: 262.639.6670 • Fax: 262.417.1155

www.blancett.com

 Racine Flow Meter Group *Blancett* DYNASONICS Flo-tech HEDLAND PRESO racine

BLANCETT and QUIKSERT are registered trademarks of
Racine Federated Inc.

UL is a registered trademark of Underwriters Laboratories.

© 2009 Racine Federated Inc.

Printed in USA
Form No. B430-002 06/09