

Blancett®

B2800 FLOW MONITOR

Advanced Version

- For Gas or Liquid Meters -

PROGRAMMING & INSTALLATION MANUAL



8635 Washington Avenue

Racine, Wisconsin 53406

Toll Free: 800.235.1638

Phone: 262.639.6770 • Fax: 262.417.1155

www.blancett.com



TABLE OF CONTENTS

Introduction	4
Specifications.....	5
Operating the Monitor	6
Advanced Programming Mode	6
Programming	7
4-20 mA Programming.....	10
Linearization	12
Password.....	12
Battery Replacement	13
Additional Input Options	14
Circuit Board Diagrams	15
Programming Menus	16
Mounting Options / Dimensions	18
Additional Scaling Parameters.....	20
Troubleshooting.....	23
Installation Drawing.....	25
Statement of Warranty	26

NOTE: *Blancett reserves the right to make any changes or improvements to the product described in this manual at any time without notice.*

INTRODUCTION

The B2800 Flow Monitor is a state-of-the-art, digital signal processing flow monitor, designed to provide the user with exceptional flexibility at a very affordable price. Though designed for use with Blancett flow meters, this display can be used with almost any flow meter producing a low amplitude AC output or contact closure signal(s).

This flow monitor is capable of accepting a low-level frequency input for calculating flow rate and total. These calculations can then be displayed in the desired units of measurement. All B2800 Flow Monitors come pre-programmed from the factory, if ordered with a Blancett flow meter. If required, however, it can easily be re-configured in the field. The monitor's large 8 digit by .75" numeric liquid crystal display makes extended range viewing practical. The second 8 digit by .38" alphanumeric display provides for selectable units viewing in run mode and prompts for variables in program mode. Finally, the user can choose between displaying rate, total, or alternating between both rate and total.

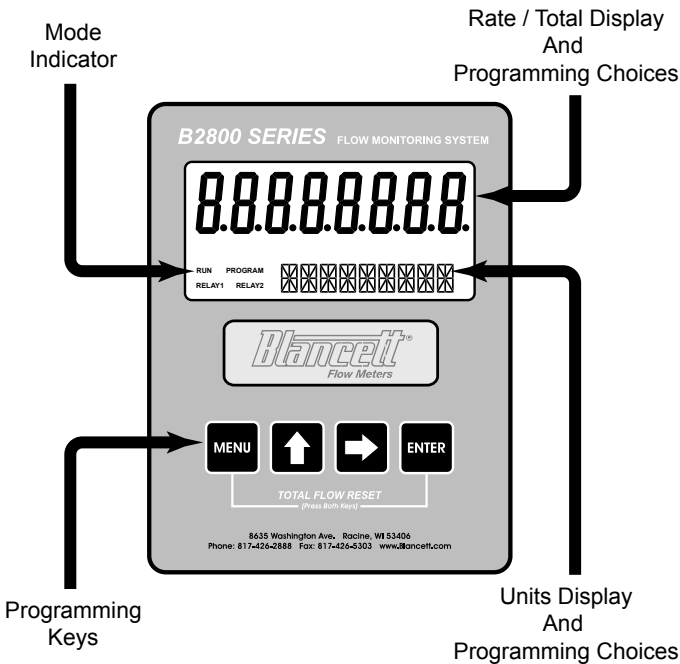

FIGURE 1
B2800 Flow Monitor

SPECIFICATIONS

Power Supply Options:

Battery Powered: 1 "D" size, 1.5 Volt alkaline battery

Loop Powered: Optional 4-20 mA loop power

Power Consumption:

Battery Powered: Less than 1 milliwatt

Loop Powered: 25 mA (maximum)

Alphanumeric Rate and Total Display:

8 digit, .75" high numeric display

8 character, .38" high alphanumeric display

Fixed or toggle modes of operation for flow rate and totalizer display

Pulse Output Signal:

One pulse for each increment of the least significant totalizer digit

Pulse Type: Opto-isolated open collector transistor

Maximum Voltage: 30 Vdc

Pulse Width: (ON state) 20 mS / max pulse rate 20 Hz

Current: (ON state) 0.9 V drop @ 5.0 mA or 0.7 V drop @ 0.1 mA

Inputs:

Magnetic Pick-up Input

Frequency Range: 0 to 3500 Hz

Trigger Sensitivity: 30 mV p-p

Over Voltage Protected: ± 30 Vdc

Accuracy: $\pm 0.1\%$

Temperature Drift: 50 ppm / $^{\circ}\text{C}$ (maximum)

Analog Output (Loop Powered Version):

4-20 mA Current Loop

Resolution: 1:4000

Environmental:

Operating Temperature: -22°F to $+158^{\circ}\text{F}$ (-30°C to $+70^{\circ}\text{C}$)

Humidity: 0-90% Non-condensing

Enclosure Rating:

Meter, Remote and Swivel Mount: NEMA/UL/CSA Type 4X (IP-66)

Transient Overvoltages: Category 3, in accordance with IEC664

Pollution Degree: 2, in accordance with IEC664

Certifications:

CSA: Class I, Div 1 Groups C, D; Class II, Div 1 Groups E, F, G

UL: Class I, II, III Div 1 Groups C, D

CE: IEC 61326-1

Units of Measure:

Gallons, Oil Barrels, Liters, Cubic Meters, MGal, Cubic Ft, MLiters, MCF, MMCF, Acre Ft, Liq Barrels, Lbs, Kgs

Time Intervals: Day, Hour Minute, Second

OPERATING THE MONITOR

The monitor has two modes of operation referred to as the RUN mode and the PROGRAM mode. Both the RUN mode and the PROGRAM mode display screen enunciators confirming the state of the monitor. A quick glance at the lower left-hand corner of the LCD screen will confirm operating status. Normal operation will be in the RUN mode. To access the PROGRAM mode, press the MENU button until the first programming screen is displayed. After programming the display with the necessary information, a lock out feature can be turned on to prevent unauthorized access or changing the meter's setup parameters.

ADVANCED PROGRAMMING MODE

Keys:

MENU – Switches between RUN and PROGRAM modes

UP Arrow – Scrolls forward through the parameter choices and increments numeric variables

RIGHT Arrow – Scrolls backward through the parameter choices and moves the active digit to the right

ENTER – Used to save programming information, advance to the next programming parameter, and in the reset process

Modes:

RUN – Normal operating mode

PROGRAM – Used to program variables into the display

If your monitor was ordered with a Blancett flow meter, the two components ship from the factory calibrated as a set. If the monitor is a replacement, the turbine's K-factor has changed, or the monitor is being used with some other pulse generating device; programming will be necessary.

PROGRAMMING USING PULSE OUTPUT TURBINE FLOW METERS

Each turbine flow meter is shipped with either a K-factor value or frequency data. If frequency data is provided, the data must be converted to a K-factor before programming the monitor. K-factor information, when supplied, can usually be found on the neck of the flow meter or stamped on the flow meter body. The K-factor represents the number of pulses per unit of volume. The K-factor will be needed to program the monitor readout.

ENTER PROGRAM MODE – Change to PROGRAM mode by pressing the MENU button once. The mode indicator will change from RUN to PROGRAM.

NOTE: If any input value exceeds the meter's capabilities for that particular parameter, the LIMIT indicator will begin to flash indicating an invalid entry. Press ENTER once to return to the parameter's entry screen to reenter the value.

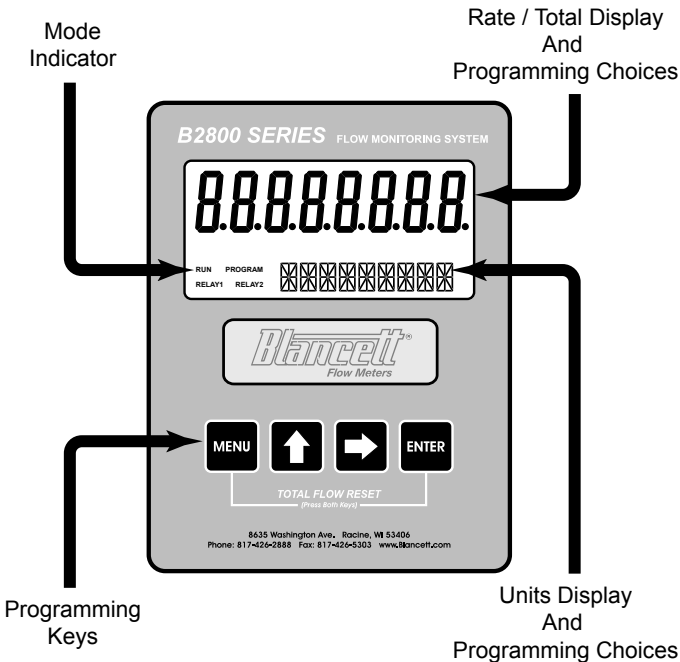

FIGURE 2
B2800 Flow Monitor

SELECT METER SIZE – At the METER prompt, press ENTER once. The current meter size number will begin to flash. Using the arrow keys, scroll through the size choices to select the bore size of your meter. Press ENTER once to save meter size choice.

NOTE: *The meter connection size and the bore size are different. For example, many of the 1" NPT turbines have bore sizes that range from 3/8" up to 1". Be sure to use the correct bore size or the meter will report incorrect flows and totals.*

SELECT DISPLAY FUNCTION – The monitor can display RATE or TOTAL or alternate between BOTH rate and total. At the DISPLAY prompt, press the ENTER key once. The monitor now shows the display mode currently in effect. To change to an alternate display mode, use the arrow keys to scroll to the desired display mode and press ENTER to save the choice.

SELECT RATE UNITS OF MEASURE – The monitor allows the choice of many common rate units. (See the "Specifications" section for a complete listing of the unit choices.) At the RATE UNT prompt, press the ENTER key once. The monitor now shows the current rate unit. If the current selection is correct, press the ENTER key to advance to the next parameter. To change to an alternate unit, use the arrow keys to scroll to the desired rate unit and press ENTER to save the choice.

SELECT RATE (TIME) INTERVAL – The term rate implies that something is occurring over a period of time. Most people are familiar with the rate of speed of a car reported in miles per hour (MPH). The same concept holds true for a flow meter. The time choices are SEC (seconds), MIN (minutes), HOUR (hours), and DAY (days). At the RATE INT prompt, press the ENTER key once. The monitor now shows the current time interval. If the current selection is correct, press the ENTER key once to advance to the next parameter. To change to an alternate time interval, use the arrow keys to scroll to the desired time interval and press ENTER to save the choice.

NOTE: *If flow rate is the only measurement of interest, skip to KFAC UNT to complete the programming process.*

SELECT TOTAL UNITS OF MEASURE – If a flow amount is desirable, the units for the total must first be chosen. The monitor allows the choice of many common totalization units. (See the "Specifications" section for a complete listing of the unit choices.) At the TOTAL UNT prompt, press the ENTER key once. The monitor shows the current total units. If the current selection is correct, press the ENTER key once to advance to

the next parameter. To change to an alternate unit, use the arrow keys to scroll to the desired totalization unit and press ENTER to save the choice.

NOTE: *This unit of measure does not have to reflect the rate unit you have previously chosen. Example: Rate Units = Gallons, Total Units = Barrels*

SELECT TOTAL'S DISPLAY MULTIPLIER – The monitor has a very versatile display that has the ability to accumulate the flow total in multiples of ten. For example, if the most desirable totalization unit is 1,000 gallons, the monitor can easily be set up for this requirement. Once the unit is back in RUN mode, every time the total display increments by one digit the actual total would be an additional 1,000 gallons. At 1,000 gallons the total display would read 1, at 3,000 gallons the total display would read 3, etc. This feature eliminates having to look at a total, count the digits and mentally insert commas for each 1,000 multiple.

At the TOTL MUL prompt, press the ENTER key once. The monitor now shows the current total multiplier. If the current selection is correct, press the ENTER key to advance to the next parameter. To change to an alternate multiplier, use the arrow keys to scroll to the desired multiplier unit and press ENTER to save the choice.

Multiplier Choices: 0.01, 0.1, 1, 10, 100, 1000, 10000, 100000 and 1000000 units

NOTE: *The K-factor supplied with the meter or calculated from calibration data will be needed to complete the next step.*

ENTER METER'S K-FACTOR UNIT – At the KFAC UNT prompt, press the ENTER key once. The display now shows the current K-factor unit. If the current selection is correct, press the ENTER key to advance to the next parameter. For meters calibrated in gallons, use PUL/GAL; for meters calibrated in cubic meters, use PUL/M3; etc.

SCALE FACTOR – At the SCALE F prompt, press the ENTER key once. The current scale factor will begin to flash. If the current selection is correct, press the ENTER key to advance to the next parameter. The scale factor is used to force a global change to all variables. For example, under operating conditions the display is reading a consistent 3% below the expected values at all flow rates. Rather than changing all parameters individually, the scale factor can be used to compensate for the 3% offset. The scale factor would be set to 1.03 to correct the readings. The range of scale factors is from 0.5 to 1.5. The default scale factor is 1.0.

METER TYPE – At the METERTYP prompt, press the ENTER key once. The current meter type will be displayed as “Liquid” or “Gas”. If the current selection is correct, press the ENTER key to advance to the next parameter. If “Gas” is selected, operating pressure (PSIG) and operating temperature (°F) must be entered before advancing to the next parameter.

DAMPING FACTOR – At the DAMPING prompt, press the ENTER key once. The current damping setting will begin to flash. If the current selection is correct, press the ENTER key to advance to the next parameter. The damping factor is increased to enhance the stability of the flow readings. Damping values are decreased to allow the flow meter to react faster to changing values of flow. This parameter can take on any value between 0 and 99 with 0 being the default.

TOTALIZER PULSE OUTPUT – The pulse output parameter can be either enabled or disabled. When enabled, this output generates 20 mS duration pulse for every time the least significant digit of the totalizer increments. The amplitude of the pulse is dependent on the voltage level of the supply connected to the pulse output and is limited to a maximum 30 Vdc.

NOTE: *The 4-20mA “zero” and “span” values are not factory set.*

FLOW 4 mA SETTING – When the loop powered option is ordered, the flow rate that corresponds to 4 mA must be set. If the current selection is correct, press the RIGHT arrow key once to advance to the next parameter. If adjustment is required, press the ENTER key once at the FLOW 4MA prompt. The most significant digit will begin to flash. The RIGHT arrow key moves the active digit one place to the right for each press of the key. The UP arrow key increments the active digit one integer for each press of the key. When the correct 4 mA flow rate has been entered, press ENTER once to store this value and move to the next parameter.

FLOW 20 mA SETTING – Follow the same programming process as the FLOW 4MA except for the flow rate setting. In this case, use the maximum flow rate for the meter.

4-20 mA CALIBRATION – When ordered with a 4-20 mA option, this menu item allows the fine adjustment of the 4-20 mA output. The 4 mA setting is typically between 35 and 50. To set the 4 mA value, connect an ammeter in series with the loop power supply. See **Figure 3**. At the 4-20CAL prompt, press ENTER once. The display will now show a steady NO indication. Press the UP arrow key to change to a flashing YES display. Press ENTER once to access the 4 mA fine adjustment.

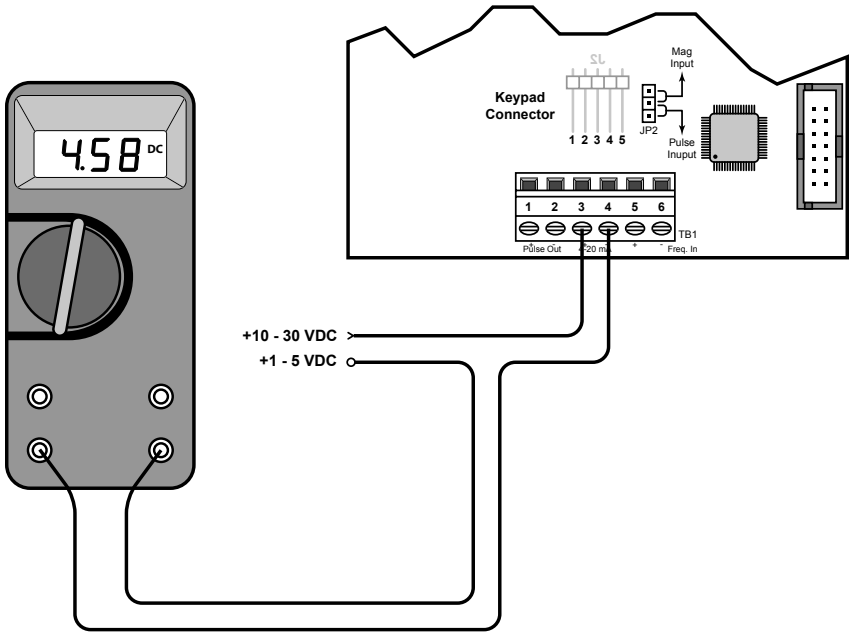

FIGURE 3
Typical Ammeter Connection

4 mA ADJUSTMENT – While monitoring the ammeter, adjust the 4 mA value to obtain a 4 mA reading. The UP arrow key increments the value and the RIGHT arrow key decrements the value. When a steady 4 mA reading is obtained on the ammeter, press the ENTER key to lock in this value and move to the 20 mA adjustment.

20 mA ADJUSTMENT – The 20 mA adjustment is performed using the same procedure as the 4 mA adjustment. While monitoring the ammeter, adjust the 20 mA value to obtain a 20 mA reading. The UP arrow key increments the value and the RIGHT arrow key decrements the value. When a steady 20 mA reading is obtained on the ammeter, press the ENTER key to lock in this value and move to the next parameter.

4-20 mA TEST – The monitor contains a diagnostic routine that allows the simulation of mA values between 4 and 20 to check output tracking. At the 4-20TEST prompt, the arrow keys change the simulated mA output in increments of 1 mA. The ammeter should track the simulated mA output. If a 4-20 mA test is not necessary, press the ENTER key once to move to the next parameter.

LINEARIZATION – Enhanced accuracy can be obtained by linearization of the display. The linearization routine will accept a maximum of ten points. Linearization requires additional calibration data from the meter to be used with the monitor. Typically, calibration information can be obtained in three, five, and ten points from the flow meter’s manufacturer. If linearization is not needed, press the RIGHT arrow key to advance to the next parameter. (See “Additional Scaling Parameters” for more information.)

Number of Points – At the LINEAR prompt, press ENTER once. The NUM PTS value will be displayed. Press ENTER to set the number of points to be used. Again, the UP arrow key increments the value and the RIGHT arrow key moves the cursor between digits. When the number of points has been input, press the ENTER key once to move to the first linear segment.

Press the ENTER key once and the first linear point’s frequency input will begin to flash (FREQ 1). Enter the frequency for the first linear point using the arrow keys. When the frequency value input is complete, press ENTER once again to change to the coefficient value for the first linear point.

Coefficient – The coefficient is the value applied to the nominal K-factor to correct it to the exact K-factor for that point. The coefficient is calculated by dividing the actual K-factor for that point by the average K-factor for the flow meter.

$$\text{Coefficient} = \text{Actual K-factor} \div \text{Average K-factor}$$

At the COEFF prompt, enter the coefficient that corresponds to the frequency value previously entered. Press ENTER once to move to the scaling point.

Continue entering pairs of frequency and coefficient points until all data has been entered. Press the MENU key twice at the NUM PTS prompt to exit to the LINEAR prompt. Press the RIGHT arrow key to move to the next parameter.

PASSWORD – Password protection prevents unauthorized users from changing programming information. Initially, the password is set to all zeros. To change the password, press ENTER once at the PASSWORD prompt. The first digit of the password will begin to flash. Using the arrow keys as previously described, enter the password value. Pressing ENTER once will store the password and take you back to the RST PSWD screen.

NOTE: *This password will allow the operator to manually reset totals.*

RST PSWD – Reset password protection prevents unauthorized users from manually resetting the flow monitor's accumulated totals. Initially, the password is set to all zeros. To change the password, press ENTER once at the RST PSWD prompt. The first digit of the password value will begin to flash. Using the arrow keys as previously described, enter the password value. Pressing ENTER once will store the password and take you back to the METER size screen. Pressing MENU exits the PROGRAM mode. The B2800 Flow Monitor is now ready to use with its companion meter.

NOTE: *Entering a password in the PASSWORD screen and leaving the password blank in the RST PSWD screen allows for total resets (not requiring a password), but restricts programming modification.*

RESET TOTAL – To reset the monitor's total display, in RUN mode, press the MENU and ENTER simultaneously until TOTAL RST starts to flash. The TOTAL RST will stop flashing and the display will return to the RUN mode at the conclusion of the reset procedure.

STORE TOTAL – The current total can be manually stored in the monitor's flash memory. This procedure may be desirable prior to changing the settings or replacing the battery. Press and hold the ENTER key for 2 seconds. The display will respond with a flashing TOTALSVD and then return to the RUN mode.

AUTOMATIC STORE TOTAL – The monitor is equipped with a store total feature that works automatically, saving the current total to flash memory. The frequency of saves depends on the power supply option chosen.

Battery Powered: Once per hour and just before a low battery condition turns the unit off.

Loop Powered: Once every ten minutes.

BATTERY REPLACEMENT

Battery powered monitors use a single 1.5 V, "D" size, alkaline battery. When replacement is necessary, use a clean fresh battery to ensure continued trouble-free operation. It is recommended that the total be saved to memory before the battery is removed. (See "STORE TOTAL".)

Unscrew the two captive screws on the front panel to gain access to the battery. Replace the battery being sure to observe the proper polarity, and then re-fasten the front panel.

ADDITIONAL INPUT OPTIONS

The B2800 Flow Monitor is capable of receiving magnetic pick-up input (small signal sine wave) or a contact closure input (pulse). Since most Blancett turbine flow meters utilize a magnetic pick-up, the B2800 Flow Monitor is shipped configured for magnetic pick-up input. To change to a contact closure input, remove JP2 from the **top** two pins and jumper them to the **bottom** two pins. See **Figure 5** on page 15.

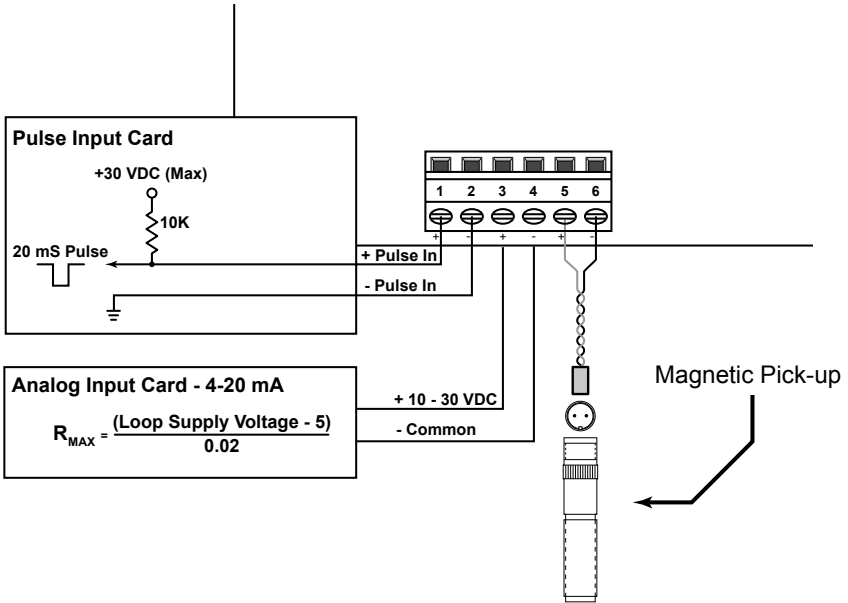
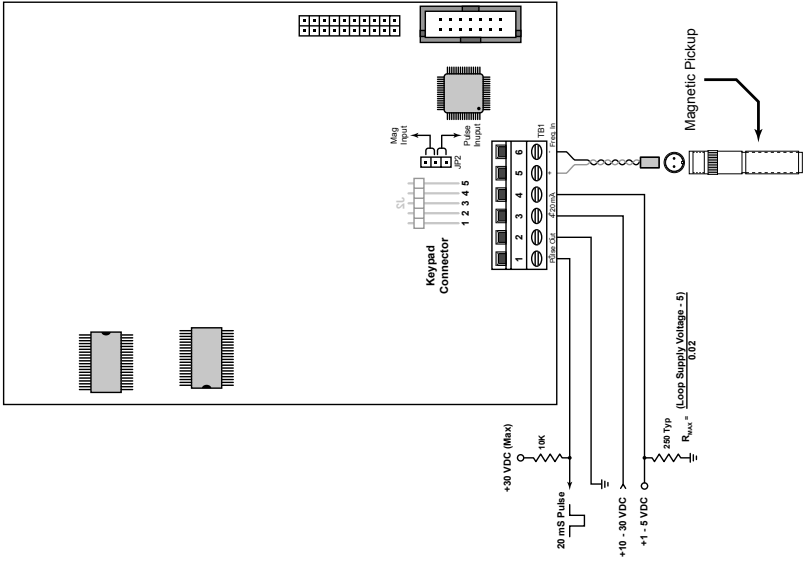
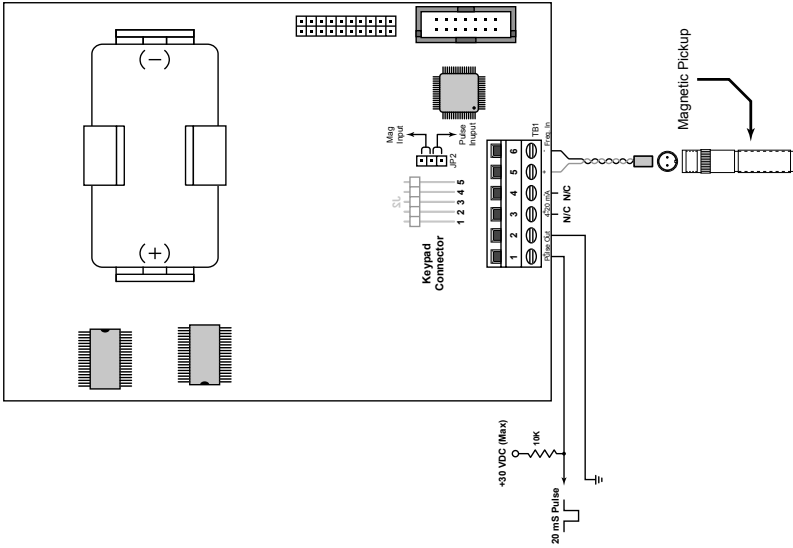

FIGURE 4
Wiring Diagram



LOOP POWERED



BATTERY POWERED

FIGURE 5
Circuit Board Layouts

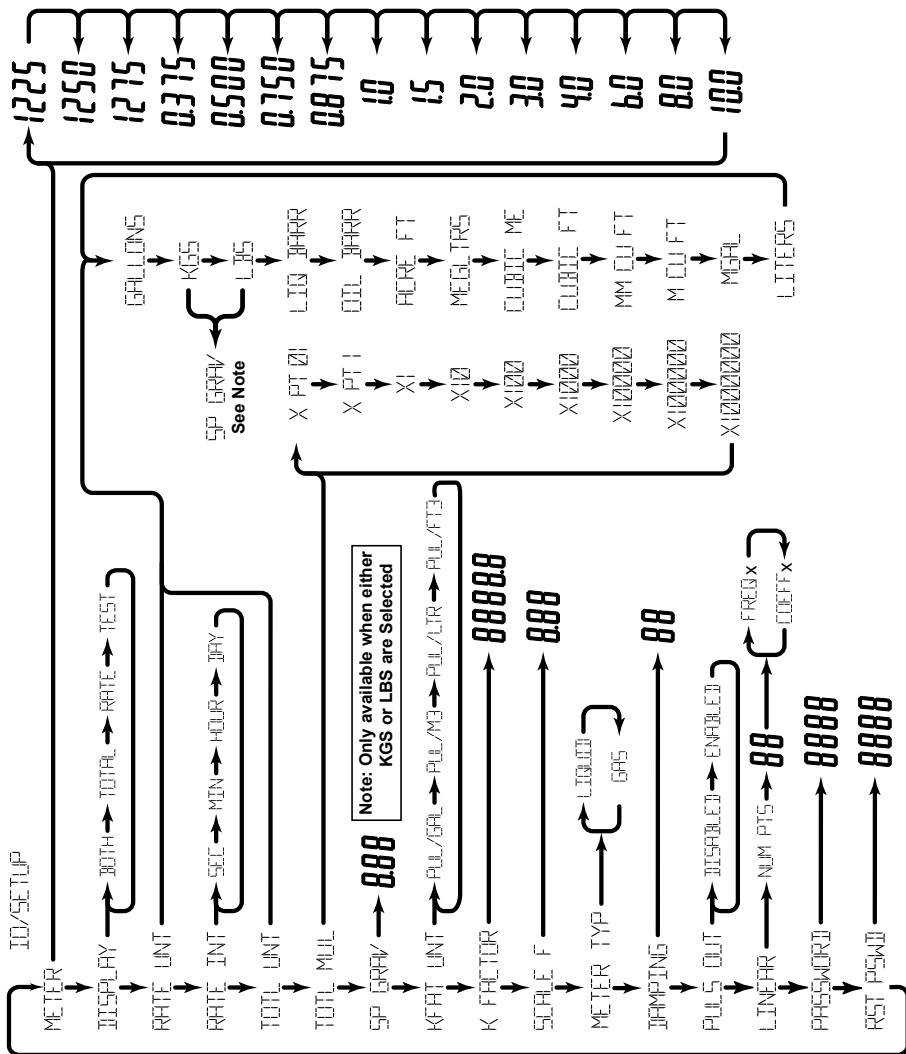

FIGURE 6
Advanced Programming Menu

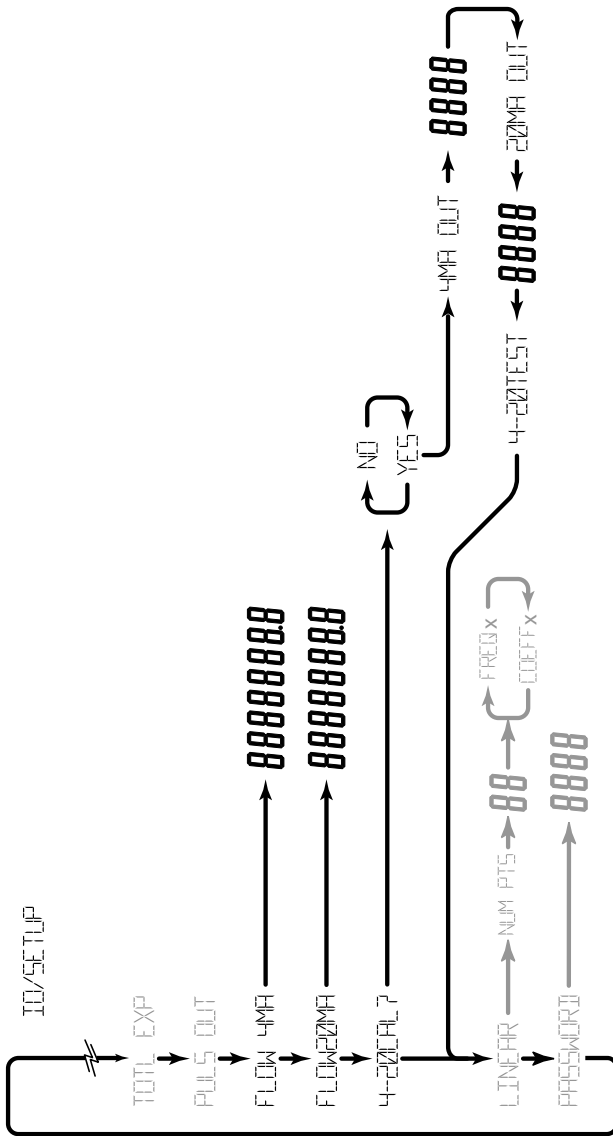

FIGURE 7
4-20 mA Programming Menu

MOUNTING OPTIONS / DIMENSIONS

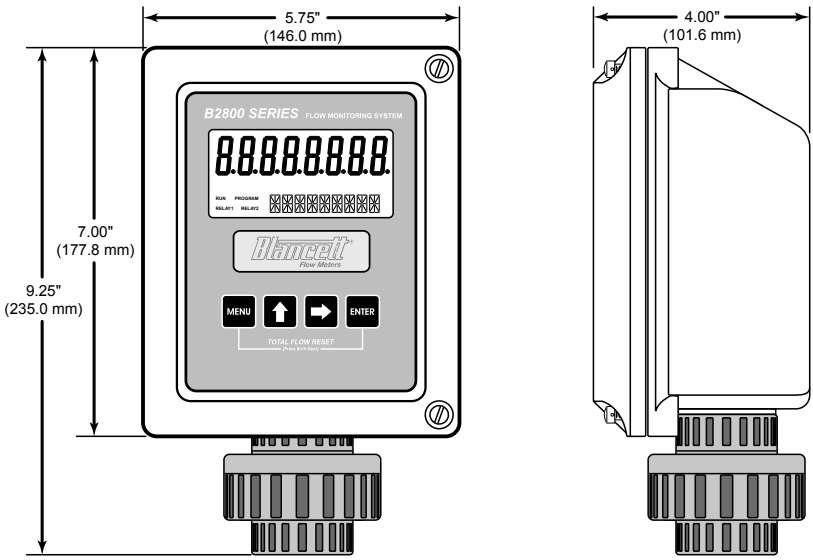

FIGURE 8
Meter Mount

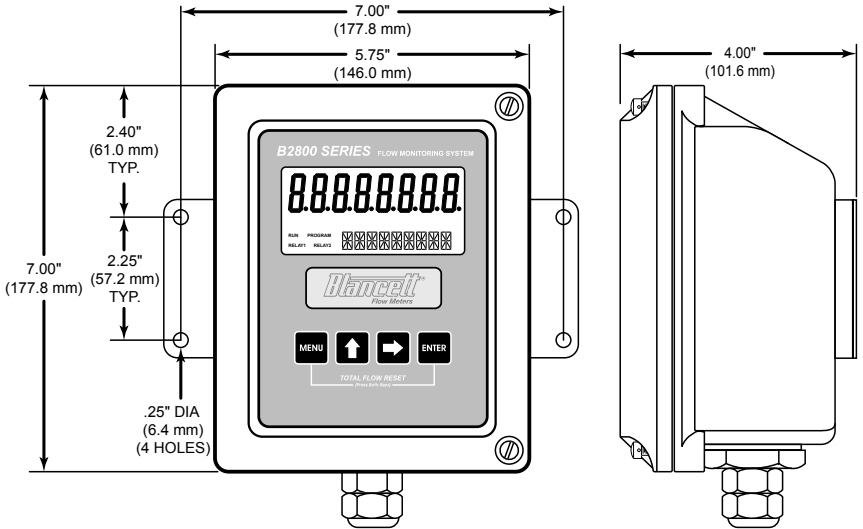

FIGURE 9
Remote Mount

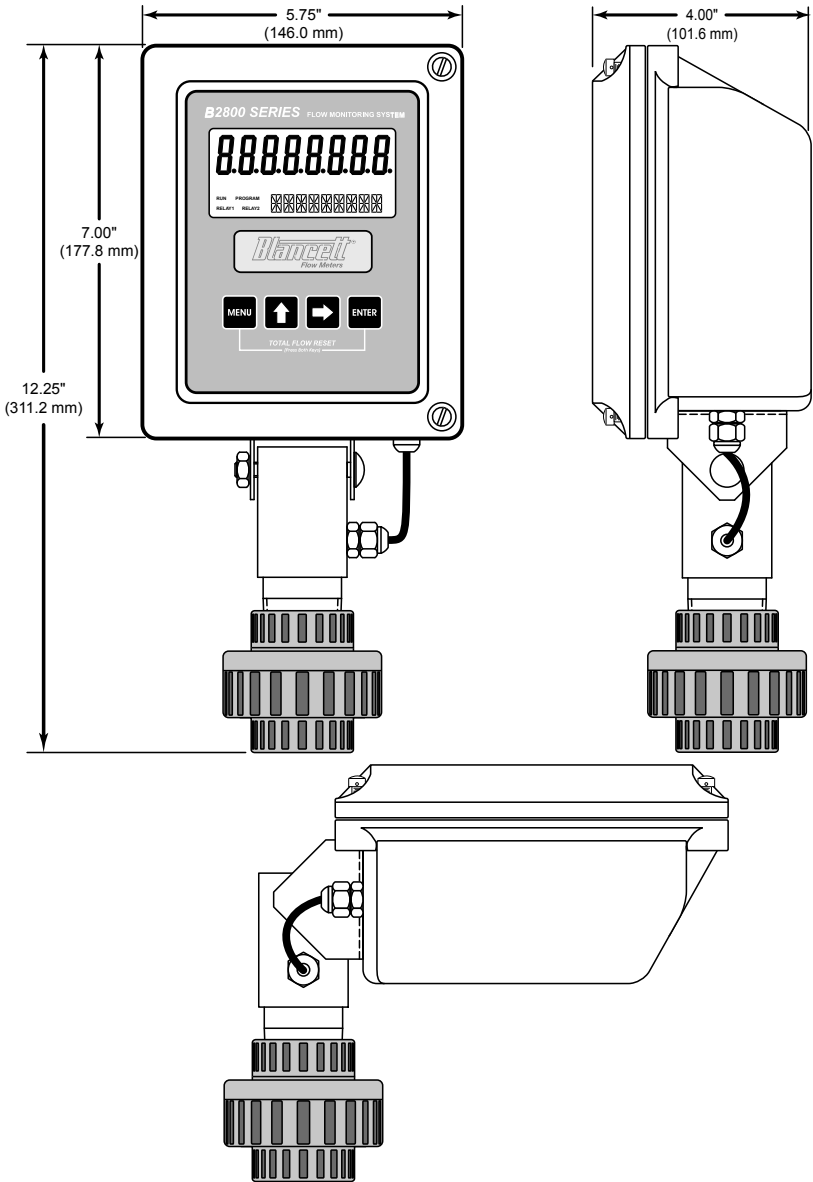

FIGURE 10
Swivel Mount

ADDITIONAL SCALING PARAMETERS

This information is supplied as a general introduction to the basic concepts used to scale rate displays. The applicability of the information is dependent on the type and capabilities of the specific display/monitor used.

Flow meters producing an electronic signal are normally supplied in one of two output formats. The pulse format generates some form of alternating signal that can be "raw", that is no amplification or wave shaping can be done prior to transmission to the readout. The output pulse rate is related proportionally to flow rate. Pulses can also be modified to produce higher output amplitudes or specific wave shapes.

The other output format is an analog signal. This is a continuous, variable voltage or current signal that is normally scaled to the dynamic range of the meter. Typical analog signals are 0-5 Vdc, 0-10 Vdc, and 4-20 mA. The analog signals may or may not be derived from a raw pulse signal produced by the flow meter.

Scaling for any of these input signals always requires at least two scaling points for a linear process - zero or minimum flow point and the maximum flow point. Additionally, each scaling point has two components, the actual input signal value and the desired display value at that input signal for that scaling point.

For example, a pulse output flow meter has a flow of 50 GPM at a pulse rate of 100 Hz. The actual input signal is the 100 Hz figure, but allowing the display to read "100" would be meaningless to the operator. The solution to this problem is to "scale" the display to "read" 50 (GPM) when the input is 100 Hz.

Pulse Output Signals for Linear Processes (where linearization is not necessary)

Pulse output signals are related to flow rate by a constant, usually referred to as the "K-factor". The K-factor is reported as the number of accumulated pulses that represents a particular volume such as gallon or liter. K-factors are indicated in pulses per unit volume or counts per unit volume. An example of a K-factor, normally supplied by the manufacturer, might be 2000 counts per gallon. The K-factor is correlated to flow through a simple mathematical relationship:

$$\text{Frequency} = \text{K-factor} \times \text{Volume per unit of time} \div 60$$

Using the previous example of 2000 counts per gallon and further assuming this meter has a maximum flow rate of 25 GPM, the formula can be arranged to calculate the input frequency required for a scaling point as follows:

$$\text{Frequency} = 2000 \times 1 \text{ (gal)} \div 60 = 33.333 \text{ Hz at 1 GPM}$$

Given that the meter has a maximum flow rate of 25 GPM, the maximum frequency would then be:

$$\text{Frequency} = 2000 \times 25 \text{ (gal)} \div 60 = 833.333 \text{ Hz at 25 GPM}$$

A programmable display requires at least two points. The first point is the zero or minimum flow and the second is normally the maximum flow rate. For the imaginary flow meter used in the example above, the scaling would be as follows:

Input Value for Scaling Point 1	=	0
Display Value for Scaling Point 1	=	0
Input Value for Scaling Point 2	=	833.33
Display Value for Scaling Point 2	=	25

**Pulse Output Signals for Non-linear Processes
(applications that can benefit from linearization)**

Few flow meters actually behave in a linear way. There is always some uncertainty about the “exact” flow at a given reported input value. For many common flow measurement applications, the assumption of linear flow is adequate for the process being measured. When higher accuracy is required, a technique called “Linearization” is often employed.

When the flow meter is being calibrated, multiple data points are obtained for the particular meter being tested. A typical five point calibration run is displayed below.

GPM	AVG Frequency	** UUT Hz Counts/GAL	UUT K(Hz×60)÷NK GPM	Error %FS
15.00	769.7	3078.59	14.90	-0.65
9.06	466.1	3086.75	9.03	-0.38
5.49	285.2	3118.64	5.52	0.65
3.32	171.7	3103.95	3.32	0.17
2.00	103.6	3101.80	2.01	0.10

*** UUT = Unit Under Test*

If this meter produced an actual linear output, the K-factor calculation for the Unit Under Test would be exactly the same for each measurement point. Inspection of the UUT K in the example provided shows that this is not the case and indicates that this meter is not a perfectly linear device.

Many programmable displays allow for linearization and can provide a better match of the displayed flow values with the actual flow values by incorporating more measurement points. In the example, the unit would be programmed for six points, the five data points and a zero point, and use pairs of input values to accomplish the linearization.

TROUBLESHOOTING GUIDE

Trouble	Remedy
No LCD Display	<ul style="list-style-type: none"> • Check battery voltage. Should be 1.5 Vdc. Replace if low or bad.
No Rate or Total Displayed	<ul style="list-style-type: none"> • Check connection from meter pick-up to display input terminals. • Check turbine meter rotor for debris. Rotor should spin freely. • Check programming of flow monitor.
Flow Rate Display Interprets Reading Constantly	<ul style="list-style-type: none"> • This is usually an indication of external noise. Keep all AC wires separate from DC wires. • Check for large motors close to the meter pick-up. • Check for radio antenna in close proximity. • Try disconnecting the pick-up from the monitor pig tail. This should stop the noise.
Flow Rate Indicator Bounces	<ul style="list-style-type: none"> • This usually indicates a weak signal. Replace pick-up and/or check all connections. • Examine K-factor.

DEFAULT K-FACTOR VALUES

Meter Size	Default K-factor	Lower Limit	Upper Limit
0.375	20,000	16,000	24,000
0.500	13,000	10,400	15,600
0.750	2,750	2,200	3,300
0.875	2,686	2,148	3,223
1.000	870.0	696.0	1,044
1.500	330.0	264.0	396.0
2.000	52.0	41.6	62.0
3.000	57.0	45.6	68.0
4.000	29.0	23.2	35.0
6.000	7.0	5.6	8.0
8.000	3.0	2.4	4.0
10.000	1.6	1.3	2.0

PART NUMBERING INFORMATION

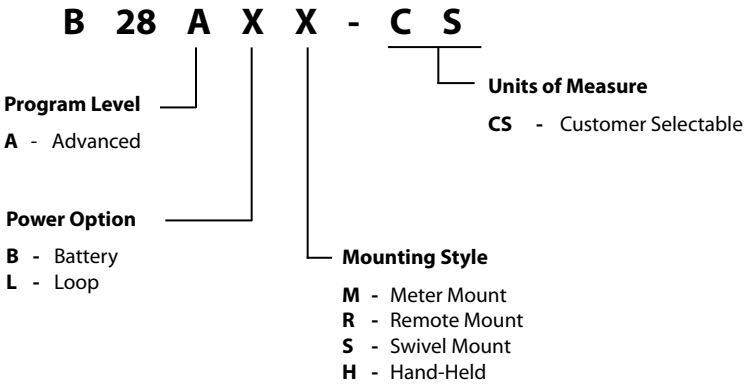

REPLACEMENT PARTS

Component	Part Number
Keypad	B260713
Battery	B280601
Battery Tie Wrap	B228036
Pick-up Cable	B222-121
Desiccant Bag	B260630
PVC Union	B220016
PVC Reducer Bushing	B220056
Rubber Washer	B228207
Steel Lock Washer	B220018
PCB Shield (battery units)	B280603
Desiccant Shield	B280680
Cord Grip	B220103

STATEMENT OF WARRANTY

Blancett Flow Meters, Division of Racine Federated Inc. warrants to the end purchaser, for a period of one year from the date of shipment from the factory, that all flow meters manufactured by it are free from defects in materials and workmanship. This warranty does not cover products that have been damaged due to defects caused by misapplication, abuse, lack of maintenance, modified or improper installation. Blancett's obligation under this warranty is limited to the repair or replacement of a defective product, at no charge to the end purchaser, if the product is inspected by Blancett and found to be defective. Repair or replacement is at Blancett's discretion. A return goods authorization (RGA) number must be obtained from Blancett before any product may be returned for warranty repair or replacement. The product must be thoroughly cleaned and any process chemicals removed before it will be accepted for return.

The purchaser must determine the applicability of the product for its desired use and assumes all risks in connection therewith. Blancett assumes no responsibility or liability for any omissions or errors in connection with the use of its products. Blancett will under no circumstances be liable for any incidental, consequential, contingent or special damages or loss to any person or property arising out of the failure of any product, component or accessory.

All expressed or implied warranties, including **the implied warranty of merchantability and the implied warranty of fitness for a particular purpose or application are expressly disclaimed** and shall not apply to any products sold or services rendered by Blancett.

The above warranty supersedes and is in lieu of all other warranties, either expressed or implied and all other obligations or liabilities. No agent or representative has any authority to alter the terms of this warranty in any way.

Blancett

8635 Washington Avenue • Racine, Wisconsin 53406

Toll Free: 800.235.1638

Phone: 262.639.6770 • Fax: 262.417.1155

www.blancett.com • info@blancett.com

RFI Racine Flow Meter Group *Blancett* **DYNASONICS Flo-tech HEDLAND PRESO racine**

BLANCETT is a registered trademark of Racine Federated Inc.

UL is a registered trademark of Underwriters Laboratories.

© 2010 Racine Federated Inc.

Printed in USA
Form No. B280-021 06/10