



## B2800 FLOW MONITOR

- For Liquid Meters -

### PROGRAMMING & INSTALLATION MANUAL

Simplified Panel Mount Version



**8635 Washington Ave.**

**Racine, Wisconsin 53406**

**Technical Toll-Free: 877.722.4631**

**Sales Toll-Free: 800.235.1638**

**Phone: 262.639.6770 Fax: 262.417.1155**

**[www.blancett.com](http://www.blancett.com)**



# TABLE OF CONTENTS

Introduction.....	4
Specifications.....	5
Operating the Monitor.....	6
Programming Mode.....	6
Programming.....	7
K-factor.....	8
Password.....	9
Totalizer.....	10
Battery Replacement.....	10
Additional Input Options.....	11
Circuit Board Layout.....	12
Enclosure Installation.....	13
Dimensions.....	14
Troubleshooting.....	15
Programming Menu.....	16
Part Numbering Information.....	17
Statement of Warranty.....	18

*Notice: Blancett reserves the right to make any changes or improvements to the product described in this manual at any time without notice.*

# INTRODUCTION

The B2800 Flow Monitor is a state-of-the-art, microprocessor based flow monitor, designed to provide the user with exceptional flexibility at a very affordable price. Though designed for use with Blancett Flow Meters, this display can be used with almost any flow meter producing a low amplitude AC output or contact closure signal(s).

This flow monitor is capable of accepting a low-level frequency input for calculating flow rate and total. These calculations can then be displayed in the desired units of measurement. All B2800 flow monitors come pre-calibrated, from the factory, if ordered with a Blancett Flow Meter. If required, however, it can easily be re-configured in the field. The monitor's large 8 digit by .75" numeric liquid crystal display makes extended range viewing practical. The second 8 digit by .38" alphanumeric display provides for selectable units viewing in run mode and prompts for variables in programming mode. Finally, the user can choose between displaying rate, total, or alternating between both rate and total.

# SPECIFICATIONS

## ***Power Supply Options:***

Battery Powered: 1 "D" size 1.5 Volt alkaline battery  
Loop Powered: Optional 4-20 mA loop power

## ***Alphanumeric Rate and Total Display:***

8 digit, .50" high numeric display  
8 character, .25" high alphanumeric display  
Fixed or toggle modes of operation for flow rate and totalizer display

## ***Accuracy:***

$\pm 0.1\%$   
Temperature Drift = 50ppm/ °C (Max)

## ***Mounting Style:***

Panel Mount (3.6" x 3.6" Opening)

## ***Environmental:***

Operating Temperature: -22 °F to 158 °F (-30 °C to 70 °C)  
Humidity: 0-90% Non-condensing

## ***Inputs:***

Magnetic Pick-up input:  
Frequency range = 0 to 3500 Hz  
Trigger sensitivity = 30 mV p-p  
Over voltage protected =  $\pm 30$  VDC

## ***Outputs:***

Opto-isolated open collector transistor  
Max. Voltage: 30 VDC  
Pulse width: 20mS/Max rate 20Hz  
Current (ON state): 0.9V drop @ 5.0 mA or 0.7V drop @ 0.1 mA  
Optional 4-20 mA output

# OPERATING THE MONITOR

The monitor utilizes two modes of operation referred to as the **RUN** mode and the **PROGRAM** mode. Both the Run mode and the Program mode display screen enunciators confirming the state of the monitor. A quick glance at the lower left hand corner of the LCD screen will confirm operating status. Normal operation will be in the **RUN** mode. To access the programming level, press the **MENU** key once. The programming indicator will appear signaling that the display is ready to accept programming inputs. After programming the display with the necessary information, a lock out feature can be turned on to prevent unauthorized access or changing the meter's setup parameters.

## BASIC PROGRAMMING MODE

### *Keys: (See Figure 1)*

**MENU** – Switches to Programming mode

**UP** Arrow – Scrolls forward through the parameter choices and increments numeric variables

**RIGHT** Arrow – Scrolls backward through the parameter choices and moves the active digit to the right

**ENTER** – Used to save programming information, advance to the next programming parameter, and in the reset process

### *Modes:*

**RUN** – Normal operating mode

**PROGRAM** – Used to program variables into the display

If your monitor was ordered with a Blancett flow meter, the two components ship from the factory, calibrated as a set. If the monitor is a replacement, the turbine's K-factor has changed, or the monitor is being used with some other pulse generating device, programming will be necessary.

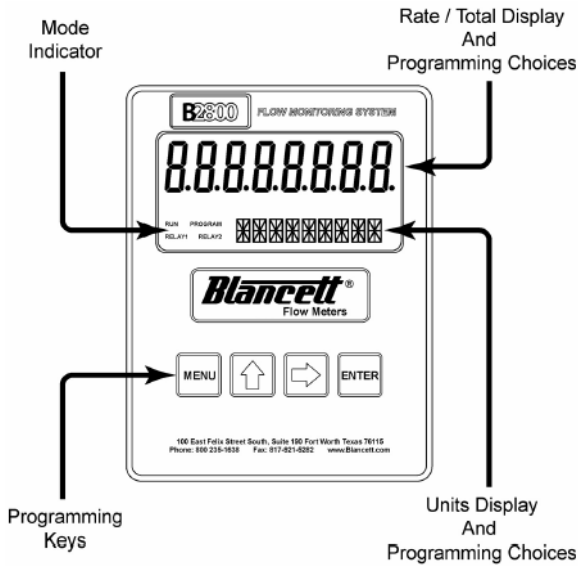

**FIGURE 1**

## Programming Using Pulse Output Turbine Flow Meters

Each turbine flow meter is shipped with either a K-factor value or frequency data. If frequency data is provided, the data must be converted to a K-factor before programming the monitor. K-factor information, when supplied, can usually be found on the neck of the flow meter or stamped on the body. The K-factor represents the number of pulses per unit of volume. The K-factor will be needed to program the monitor readout.

**ENTER PROGRAMMING MODE** – Change to programming mode by pressing the MENU button once. The mode indicator will change from RUN to PROGRAM.

**SELECT THE METER SIZE** – At the METER prompt, press the UP or RIGHT arrow keys to select the bore size of your meter. Press ENTER button once to save meter size choices and advance to the K-factor units selection.

***Note:** The meter connection size and the bore size are different. For example, many of the 1" NPT turbines have bore sizes that range from 3/8" up to 1". Be sure to use the correct bore size or the meter will report incorrect flows and totals.*

**ENTER THE METER'S K-FACTOR UNIT** – Directly after the METER size is selected, the display's K-factor unit must be chosen. Use the UP arrow key to select your K-factor unit. For meters calibrated in gallons, use PUL/GAL (pulses per gallon), for meters calibrated in cubic meters, use PUL/M3 (pulses per cubic meter), etc. Press ENTER to save the K-factor unit and advance to the next parameter.

***Note:** Unless otherwise specified, Blancett turbine flow meters are supplied with K-factors measured in pulses per gallon (PUL/GAL) which will automatically convert to your desired units of measure.*

***Note:** The K-factor supplied with the meter or calculated from calibration data will be needed to complete next step.*

**ENTER THE METER'S K-FACTOR** – To change the K-FACTOR value, use the RIGHT arrow key and select the position of the number that you wish to change. Using the UP arrow key, increment the display digit until it matches the meter's K-factor digit. Repeat this process until all K-factor digits have been entered. Press ENTER once to save the K-factor and advance to the RATE/TOTAL Units selection.

**SELECT THE RATE/TOTAL UNITS OF MEASURE** – The monitor allows the choice of five common rate/total units. The monitor shows the rate/total unit that the display is currently set for. If the current selection is current, press the ENTER key once to advance to the next parameter. To change to an alternate unit, use the arrow keys to scroll to the desired rate unit and press ENTER to save the choice.

<b>SELECTION</b>	<b>RATE</b>	<b>TOTAL</b>
GPM/GAL	Gallons per Minute	Gallons
LPM/LIT	Liters per Minute	Liters
M3PH/M3	Cubic Meters per Hour	Cubic Meters
M3PD/M3	Cubic Meters per Day	Cubic Meters
BPD/BBL	Oil Barrels per Day	Oil Barrels

***Note:** The total unit's output multiplier cannot be modified in the Simplified program level. This option is reserved in the Advanced program level.*

**SELECT THE DISPLAY FUNCTION** – The monitor can display RATE or TOTAL or alternate between BOTH rate and total. If the current selection is correct, press the ENTER key to advance to the next parameter. To change to an alternate display mode, use the arrow keys to scroll to the desired display mode and press ENTER to save the choice.

A TEST function is also available in the Display Function sub-menu. With the test function selected the display acts like a frequency counter and displays the raw input frequency being supplied to the frequency input terminals. This is very useful when troubleshooting flow problems.

**TOTALIZER PULSE OUTPUT** – The pulse output parameter can be either enabled or disabled. When enabled this output generates 20mS duration pulse for every time the least significant digit of the totalizer increments. The amplitude of the pulse is dependent on the voltage level of the supply connected to the pulse output and is limited to a maximum 30 VDC.

**PASSWORD** – Password protection prevents unauthorized users from changing programming information. Initially, the password is set to all zeros. To change the password, simply enter any 4 digit code using the arrow keys as previously de-

scribed. Pressing ENTER once will store the password and take you back to the RST PSWD screen.

*Note: This password will allow the operator to manually reset totals.*

**RST PSWD** – The reset password screen allows the operator to enter any 4 digit code for the manual reset totals function.

*Note: This reset password code will not allow the operator to enter the programming mode.*

**RESET TOTAL** – To reset the monitor total display, in run mode press the MENU and ENTER simultaneously until TOTAL RST starts to flash. The TOTAL RST will stop flashing and the display will return to the run mode at the conclusion of the reset procedure.

**STORE TOTAL** – The current total can be manually stored in the monitor's flash memory. This procedure may be desirable prior to replacing the battery. Press and hold the ENTER key for 2 seconds. The display will respond with a flashing TOTALSVD and then return to the run mode.

**AUTOMATIC STORE TOTAL** – The monitor is equipped with a store total feature that works automatically, saving the current total to flash memory. The frequency of saves depends on the power supply option chosen.

Battery Powered: Once per hour and just before a low battery condition turns the unit off.

Loop Powered: Once every ten minutes.

**BATTERY REPLACEMENT** – Battery powered monitors use a single 1.5V, "D" size, alkaline battery. When replacement is necessary, use a clean fresh battery to insure continued trouble free operation. It is recommended that the total be saved to memory before the battery is removed. (See STORE

TOTAL in the programming section of this manual).

## **ADDITIONAL INPUT OPTIONS**

The B2800 Flow Monitor is capable of receiving Magnetic Pick-up input (small signal sine wave) or a Contact Closure input (pulse). Since most Blancett Turbine Flow Meters utilize a magnetic pick-up, the B2800 flow monitor is shipped configured for magnetic pick-up input. To change to a Contact Closure input, remove JP2 from the **bottom** two pins and jumper them to the **top** two pins. **See Figure 2.**

# FIGURE 2 - CIRCUIT BOARD LAYOUT

## Battery Powered

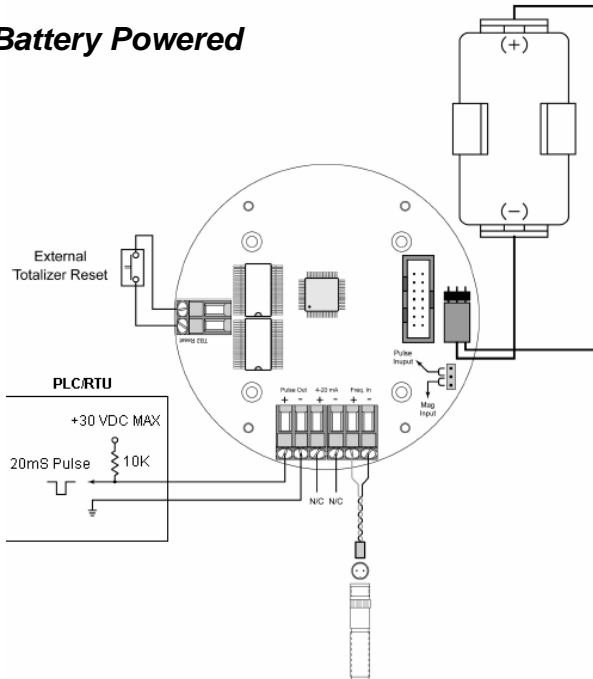

## Loop Powered

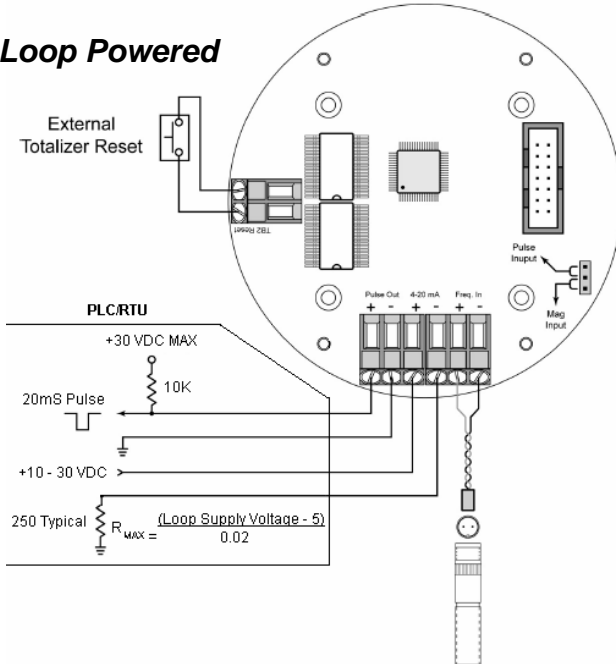

# PANEL MOUNT ENCLOSURE INSTALLATION

## Mounting Instructions

- 1) Cut a 3.6" x 3.6" square opening in your panel.  
See **Figure 3**.
- 2) Disconnect the battery from the main board terminal.
- 3) Remove the large battery mounting plate by removing the four Philips head screws from the main assembly stand-offs.
- 4) Mount the main assembly through your panel opening and temporarily hold in place (tape will work).
- 5) Attach your signal sirens to the appropriate terminal blocks.
- 6) Reattach large battery mounting plate with the four Philips head screws
- 7) Secure assembly to panel with the four outer set screws.

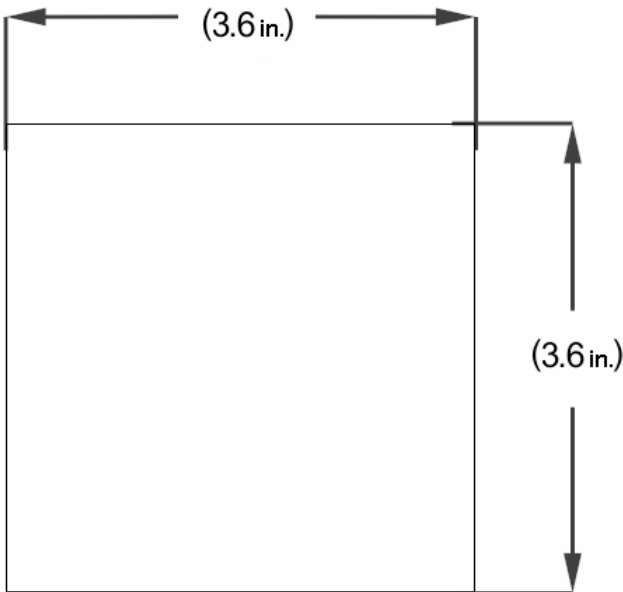

**FIGURE 3 - MOUNTING HOLE**

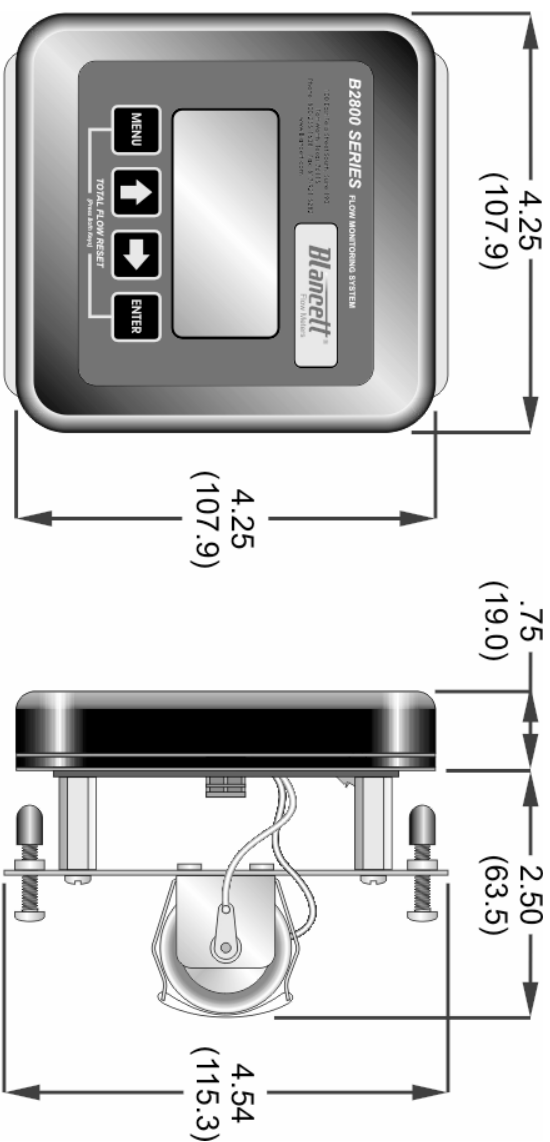
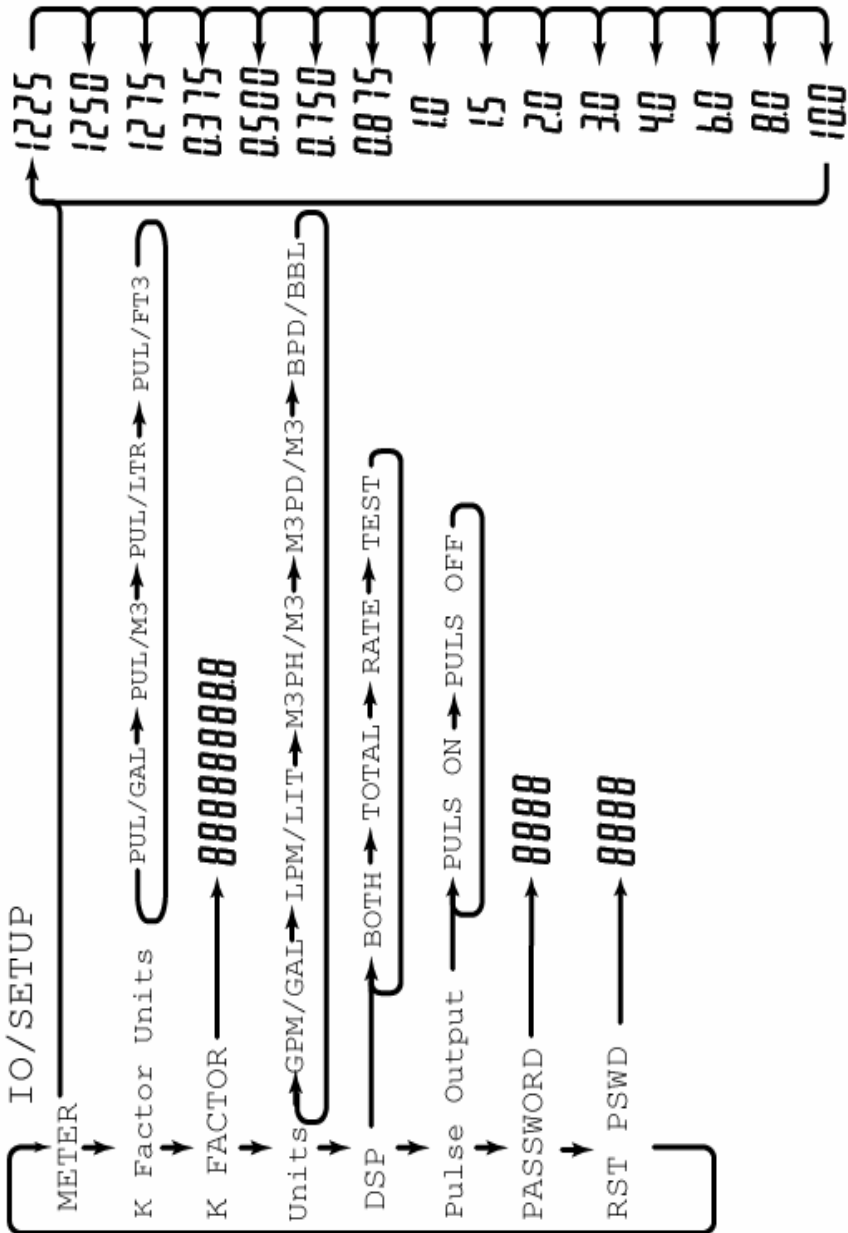

**FIGURE 4 - DIMENSIONS**

# TROUBLE SHOOTING GUIDE

Trouble	Remedy
No LCD Display	<ul style="list-style-type: none"> <li>● Check battery voltage. Should be 1.5 VDC. Replace if low or bad.</li> </ul>
No Rate or Total Displayed	<ul style="list-style-type: none"> <li>● Check connection from meter pick-up to display input terminals.</li> <li>● Check turbine meter rotor for debris. Rotor should spin freely.</li> <li>● Check Programming of flow monitor.</li> </ul>
Flow Rate Display Reads a Constant Reading All the Time	<ul style="list-style-type: none"> <li>● This is usually an indication of external noise. Keep all AC wires separate from DC wires.</li> <li>● Check for large motors close to the meter pick-up.</li> <li>● Check for radio antenna in close proximity.</li> <li>● Try disconnecting the pick-up from the monitor pig tail. This should stop the noise. If not, then try re-orientating the meter to a new location.</li> </ul>
Flow Rate Indicator Bounces	<ul style="list-style-type: none"> <li>● This usually indicates a weak signal. Replace pick-up and/or check all connections.</li> <li>● Examine K-factor.</li> </ul>

Default K-Factor Values			
Meter Size	Default K-Factor	Lower Limit	Upper Limit
0.375	20,000	16,000	24,000
0.500	13,000	10,400	15,600
0.750	2,750	2,200	3,300
0.875	2,686	2,148	3,223
1.000	870.0	696.0	1,044
1.500	330.0	264.0	396.0
2.000	52.0	41.6	62.0
3.000	57.0	45.6	68.0
4.000	29.0	23.2	35.0
6.000	7.0	5.6	8.0
8.000	3.0	2.4	4.0
10.000	1.6	1.3	2.0



**FIGURE 5 - PROGRAMMING MENU**

# PART NUMBERING INFORMATION

**B 2 8 X X X - X X**

**Program Level**

**A** = Advanced  
**S** = Simplified

**Power Option**

**B** = Battery  
**L** = Loop

**Mounting Style**

**M** = Meter Mount  
**R** = Remote Mount  
**S** = Swivel Mount  
**H** = Hand-Held  
**P** = Panel Mount  
**X** = Explosion-Proof

**Units of Measure**

**AB** = Gallons  
**ED** = Barrels  
**HB** = Liters  
**ID** = Cubic Meters  
**CS** = Customer Selectable\*

*Note: \*Advanced B2800 monitors only.  
 The default is gallons per minute.*

COMPONENT	PART NUMBER
Keypad	B260713
Battery	B280601
Battery Tie Wrap	B228036
Pick-up Cable	B222-121
Desiccant Bag	B260630
PVC Union	B220016
PVC Reducer Bushing	B220056
Rubber Washer	B228207
Steel Lock Washer	B220018
PCB Shield (battery units)	B280603
Desiccant Shield	B280680
Cord Grip	B220103

## STATEMENT OF WARRANTY

Blancett Flow Meters, Division of Racine Federated, Inc. warrants to the end purchaser, for a period of one year from the date of shipment from the factory, that all flow meters manufactured by it are free from defects in materials and workmanship. This Warranty does not cover products that have been damaged due to defects caused by abnormal use, misapplication, abuse, lack of maintenance, modified or improper installation. Blancett's obligation under this warranty is limited to the repair or replacement of a defective product, at no charge to the end purchaser, if the product is inspected by Blancett and found to be defective. Repair or replacement is at Blancett's discretion. A return goods authorization (RGA) number must be obtained from Blancett before any product may be returned for warranty repair or replacement. The product must be thoroughly cleaned and any process chemicals removed before it will be accepted for return.

The purchaser must determine the applicability of the product for its desired use and assumes all risks in connection therewith. Blancett assumes no responsibility or liability for any omissions or errors in connection with the use of its products. Blancett will under no circumstances be liable for any incidental, consequential, contingent or special damages or loss to any person or property arising out of the failure of any product, component or accessory.

All expressed or implied warranties, including **the implied warranty of merchantability and the implied warranty of fitness for a particular purpose or application are expressly disclaimed** and shall not apply to any products sold or services rendered by Blancett.

The above warranty supersedes and is in lieu of all other warranties, either expressed or implied and all other obligations or liabilities. No agent or representative has any authority to alter the terms of this warranty in any way.

# **NOTES**



**8635 Washington Avenue • Racine, Wisconsin 53406**  
**Technical Toll-Free: 877.722.4631 • Sales Toll-Free: 800.235.1638**  
**Phone: 262.639.6770 • Fax: 262.417.1155**  
**[www.blancett.com](http://www.blancett.com)**

Form: B2800 Simplified Panel Manual  
Revision 03/07